



REFRIGERATED TABLES

DEEP FREEZER TABLES

R e f r i g e r a t e d t a b l e s



The entire range has been developed to allow the greatest number of personalized combinations - even the floor supports vary from short legs to adjustable wheels. Special attention has been paid to simplifying the exchanging of doors for drawers and to adapting a series of chests of drawers.

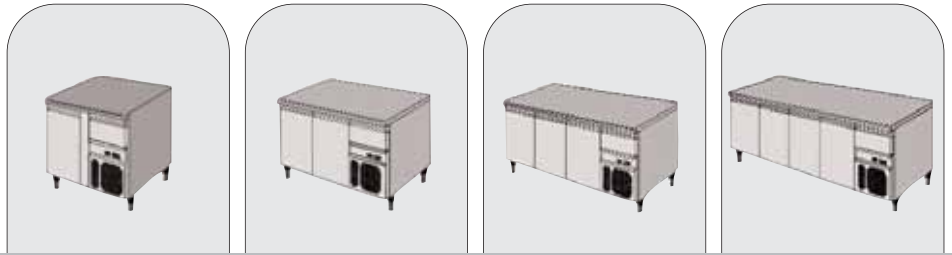

MODEL		KTAR 01	KTAR 02	KTAR 03	KTAR 04
External dimensions width	mm	1000	1396	1860	2324
depth	mm	700	700	700	700
height	mm	850	850	850	850
Voltage	V	230/1/50	230/1/50	230/1/50	230/1/50
Absorbed power (Refr./Defr.)	W	285/285	370/310	445/580	480/605
Weight	kg	116	166	216	256
Volume	m ³	0,70	1,10	1,40	1,70
Internal dimensions width	mm	896	1292	1756	2220
depth	mm	520	520	520	520
height	mm	550	550	550	550
Capacity	L	191	314	463	612
Working temperature	C°	-2/+8	-2/+8	-2/+8	-2/+8
Relative humidity	UR 96	85	85	85	85
Refrigerating capacity	Watt	125	205	300	400
Grids issued	No.	1	2	3	4
Refrigerating system		ventilated	ventilated	ventilated	ventilated
Side-access control panel					

L=150 mm

Data refers to: evaporation temperature = -10°C / atmosphere temperature = +43°C

How it works



all units in the extensive range of motorized models run at a temperature of -2 to +8°C for conserving fresh food or of -15 to -20°C for storing frozen foods. The counters which may be run by a remote compressor are equipped with built-in technical compartment which contain the electrical system, the control system and the automatic-evaporation pan. Other models are made so that the interior volume is entirely useable: for these units it is possible to order a complete control panel (optional), which is mounted on the side.

All specifically designed units feature an expansion valve.

The heavy duty compressor is built to withstand high room temperatures (tropicalized); it can run at +43°C room temperature. Innovative solutions have been developed for the evaporator in order to offer the maximum internal storage volume. All units of both the refrigerator range (temp: -2 to +8°C) as well as those of the freezer range (temp: -15 to -20°C) are fan assisted to obtain uniform temperature in all the useable space.

D e e p f r e e z e r t a b l e s

Elements: Made completely of 18/10 chrome-nickel AISI 304 stainless steel. The exteriors have a fine scotch-brite satin finish and the interiors have a high-gloss finish.

Legs: Adjustable with 30 mm variability and made completely of 18/10 AISI 304 stainless steel. Non-slot insertion.



MODEL		KTAR BT 02	KTAR BT 03	KTAR BT 04
External dimensions width	mm	1396	1860	2324
depth	mm	700	700	700
height	mm	850	850	850
Voltage	V	230/1/50	230/1/50	230/1/50
Absorbed power (Refr./Defr.)	W	480/475	670/900	750/1320
Weight	kg	165	215	255
Volume	m ³	1,10	1,40	1,70
Internal dimensions width	mm	828	1292	1756
depth	mm	520	520	520
height	mm	550	550	550
Capacity	L	268	416	565
Working temperature	C°	-15/-20	-15/-20	-15/-20
Relative humidity	UR 96			
Refrigerating capacity	Watt	340	420	530
Grids issued	No.	2	3	4
Refrigerating system		ventilated	ventilated	ventilated
Side-access control panel				

Data refers to: evaporation temperature = -30°C, atmosphere temperature = +32°C

Hygiene and cleaning

The absence of any protrusions from the bottom of the units allows them to be flush fitted to their bases or to any other type of base, for example ones made of brick and mortar, thereby assuring easy cleaning and best possible hygienic maintenance. The bottoms of all the drawers and all the corners are rounded, thereby facilitating easy cleaning. The refrigerator group is always contained in a Cr-Ni 18/10 stainless steel casing, also assuring simplicity when cleaning.



Removable condenser unit

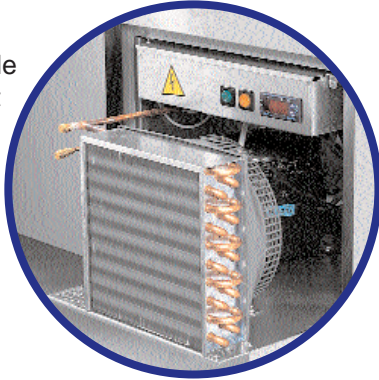

Refrigerated drawer above compressor area



Completely removable filter

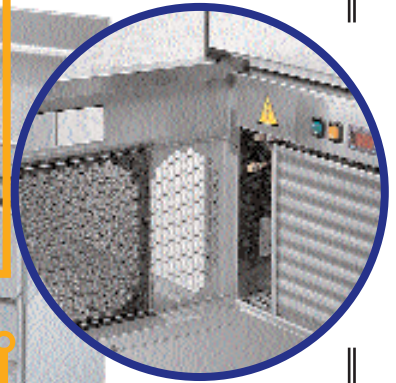

Ventilated refrigeration system (The evaporator is painted and equipped with a protection casing).

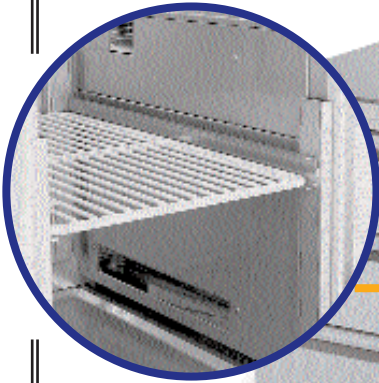

Easily cleanable cells



Automatic defrosting device



Easy access to electrical and electronic components

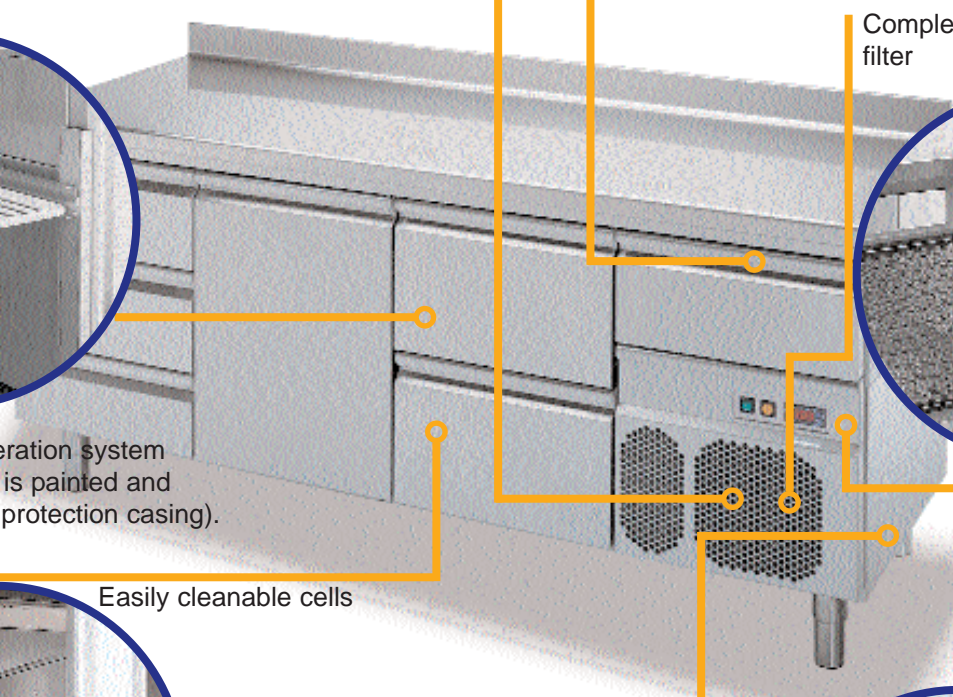

The entire range is characterized by very high performance. They are made of Cr-Ni 18/10 AISI 304 stainless steel and feature polished, corner-free interiors. The exteriors have a fine scotch-brite satin finish. The insulation is 50 mm thick and made of high-density (40 kg/m³) expanded polyurethane which is totally free of CFC, in keeping with ecology-oriented philosophy. The one-piece structure and insulation, the anticondensation resistors on the front and the use of magnetic sealing on all four double-chamber sides all guarantee a high capacity of maintaining constant temperatures - these features stand for energy saving. All the drawers are on telescopic runners, made of Cr/Ni 18/10 stainless steel and can be pulled completely out so that the GN 1/1 containers can be easily inserted and removed. In order to allow the unit to be properly installed on a base, the compressor area (which permits air circulation) is removable (and detachable) from the front.

